

- INSTALL IN CENTER OF STREET BARRICADES.
- REFLECTIVE WHITE WITH BLACK 0.5" BORDER.
- 0.080 THICK ALUMINUM
- 3" CORNER RADIUS.
- ASTM TYPE III/IV

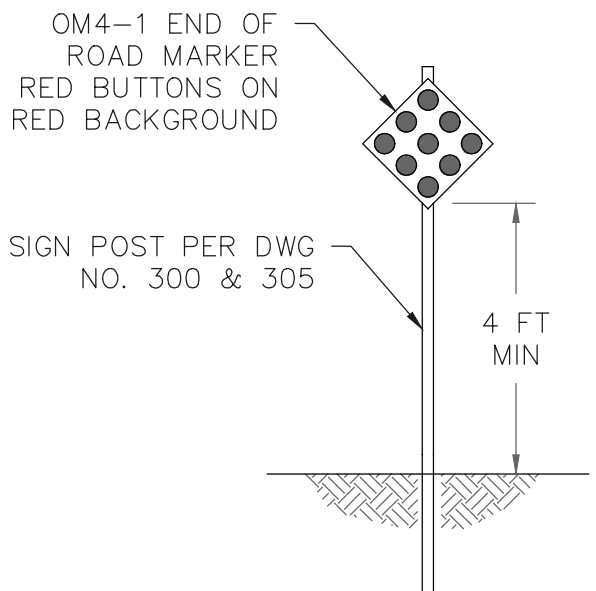

NOTES:

1. END OF STREET MARKERS SHALL BE USED TO WARN ROAD USERS OF THE END OF A STREET WHERE NO DROP OFF HAZARD EXISTS (SLOPES GREATER THAN 3:1). IF THERE IS A DROP OFF HAZARD USE DWG NO. 310.
2. SEE SECTION 2C.66 OBJECT MARKERS FOR ENDS OF ROADWAYS FROM THE MANUAL ON UNIFORM TRAFFIC CONTROL DEVICES FOR STREETS AND HIGHWAYS (MUTCD, LATEST EDITION).

**CITY OF HAPPY VALLEY
ENGINEERING DIVISION**
16000 SE MISTY DRIVE
HAPPY VALLEY, OR 97086

DWG NO: 315	END OF STREET MARKERS	
CITY ENGINEER CAROL EARLE, P.E.	DATE: 4/1/2019	REVISED BY: PCB/JHH